



Setup Guide

Regulated DC Power Supply PWR Series

400W Type

PWR400L**PWR400M****PWR400H**

800W Type

PWR800L**PWR800M****PWR800H**

1600W Type

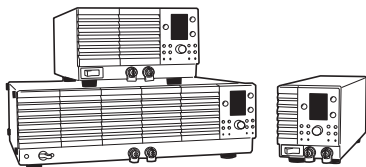
PWR1600L**PWR1600M****PWR1600H**

Thank you for purchasing the PWR regulated DC power supply series.

The PWR Series are constant voltage/current automatic crossover power supplies that are capable of delivering voltages and currents in a wide operating range within the rated output power.

KIKUSUI ELECTRONICS CORP.

1-1-3, Higashiyamata, Tsuzuki-ku, Yokohama, 224-0023, Japan
TEL: +81-45-593-0200 Fax: +81-45-593-7571

The contents of this manual may not be reproduced, in whole or in part, without the prior consent of the copyright holder.

The specifications of this product and the contents of this manual are subject to change without prior notice.

Features

- Power-factor improvement circuit
The power-factor improvement circuit reduces the effects of harmonic currents on the power line.
- High efficiency
The high power conversion efficiency reduces the cost of power and the cost of heat radiation design during system configuration.
- Communication functions
Equipped with a digital remote control function through TP-BUS (Twist Pair-BUS) communication (The total length of TP-BUS is 200 m). By combining with Kikusui's PIA4800 Series Power Supply Controller, systemization for applications such as an automatic tester is possible.
- Master-slave operation
Output voltage or output current can be expanded by connecting multiple power supplies of the same model in series (only on the L type) or in parallel. This feature allows slave units to be controlled from a single master unit.

WEBSITE

<http://www.kikusui.co.jp/en>

The newest version of the PWR manual can be downloaded from Download service of Kikusui website.

© 2012



Checking the Package Contents

When you receive the product, check that all accessories are included and that the accessories have not been damaged during transportation. If any of the accessories are damaged or missing, contact your Kikusui agent or distributor. The power cord varies depending on the type.

Accessories

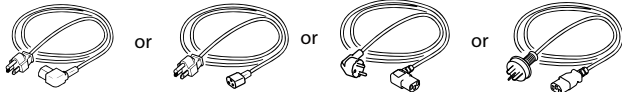

Plug : NEMA5-15
Rating : 125 Vac/10A
[85-AA-0003]

or

Plug : NEMA5-15
Rating : 125 Vac/10A
[85-10-0740]

or

Plug: CEE7/7
Rating : 250 Vac/10A
[85-10-1070]

or

Plug: GB1002
Rating: 250 Vac/10A
[85-10-0790]

The power cord that is provided varies depending on the destination for the product at the factory-shipment.

Power cord for the 400W/800W type

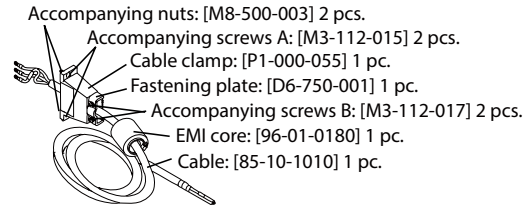

Power cord for the 1600W type (with cable clamp and no plug)

Accompanying nuts: [M8-500-003] 2 pcs.

Accompanying screws A: [M3-112-015] 2 pcs.

Cable clamp: [P1-000-055] 1 pc.

Fastening plate: [D6-750-001] 1 pc.

Accompanying screws B: [M3-112-017] 2 pcs.

EMI core: [96-01-0180] 1 pc.

Cable: [85-10-1010] 1 pc.



1 set
[Q1-500-077]

OUTPUT terminal cover

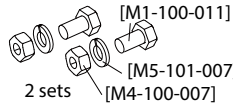

[M1-100-011]
[M5-101-007]
[M4-100-007]
2 sets

M8 output terminal screws

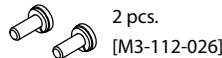

2 pcs.
[M3-112-026]

M4 output terminal screws

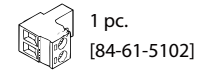

1 pc.
[84-61-5102]

TP-BUS connector

CD-ROM (1 pc.)

Safety information (1 pc.)

Setup Guide (This guide, 1 pc.)

Quick Reference
English 1 pc., Japanese 1 pc.

These parts are installed in body.

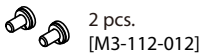

2 pcs.
[M3-112-012]

M3 sensing terminal screws

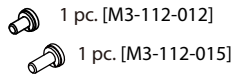

1 pc. [M3-112-012]
1 pc. [M3-112-015]

M3 screws for chassis connection wire



1 pc.
[84-49-0110]

J1 protection socket

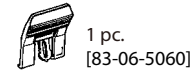

1 pc.
[83-06-5060]

J1 lock lever

About the PWR Manual

The PWR manual is intended for users of the PWR regulated DC power supply series or persons teaching other users on how to operate them.

The manual assumes that the reader has knowledge about electrical aspects of regulated DC power supplies.

The PWR manual comprises the Setup Guide (this guide), the User's Manual (Basic operation, External control, Parallel/Series operation, Maintenance, and Specifications), the Connecting & Programming Guide, the Quick Reference, and the Safety information.

The user's manual and the connecting & programming guide are provided on the accompanying CD-ROM.

Adobe Reader is required to view the PDF files. Microsoft Internet Explorer or Google Chrome is required to view the HTML files.

Put the included CD-ROM into the CD-ROM drive. In a few moments, a start window will appear. If the start window does not appear, open the CD-ROM folder in Windows Explorer, and then double-click index.html to display the start window.

Every effort has been made to ensure the accuracy of the manual. However, if you have any questions or find any errors or omissions, please contact your Kikusui agent or distributor.

If you find any misplaced or missing pages in the manual, it will be replaced. If the manual gets lost or soiled, a new copy can be provided for a fee. To replace or purchase a manual, please contact your Kikusui agent or distributor. At that time, inform your agent or distributor of the "Part No." written on the front cover of this manual.

In the manual, the PWR Series Regulated DC Power Supply is also referred to as the PWR Series and the PWR.

The display illustration used in the manual may differ from the actual displays that appear on the PWR. The screen captures are merely examples.

The PWR series is classified into three types depending on the output capacity. It is also classified into three types depending on the output voltage.

	L type (80 V)	M type (320 V)	H type (650 V)
400W type	PWR400L	PWR400M	PWR400H
800W type	PWR800L	PWR800M	PWR800H
1600W type	PWR1600L	PWR1600M	PWR1600H

The following markings are used in the explanations in the text.



WARNING

Indicates a potentially hazardous situation which, if ignored, could result in death or serious injury.



CAUTION

Indicates a potentially hazardous situation which, if ignored, may result in damage to the product or other property.

- Note -

Indicates information that you should know.

SHIFT+switch name (marked in blue)

Indicates an operation in which a switch marked in blue is pressed while holding down the SHIFT switch.

C-x: x

The first two characters "C-" indicate a configuration setting, and the next one-digit number indicates the CONFIG parameter number. The character after the colon indicates the selected setting.

Description of Operation

The PWR is a constant voltage/current regulated DC power supply that is capable of delivering voltages and currents in a wide operating range within the rated output power. Figure shows the operating area of the 400 W type.

[A] in the figure indicates the rated operating area, and [B] indicates the extended operating area. The extended operating area is valid only on the L type.

If the PWR is configured in way that satisfies the equation $\text{output voltage} \times \text{output current} \leq \text{rated output power}$, the PWR operates as a conventional constant voltage/current power supply.

If the PWR is configured in a way that satisfies the equation $\text{output voltage} \times \text{output current} > \text{rated output power}$, the actual output is limited by the power limit (approx. 105% of the rated output power) and the output voltage or output current varies depending on the load value.

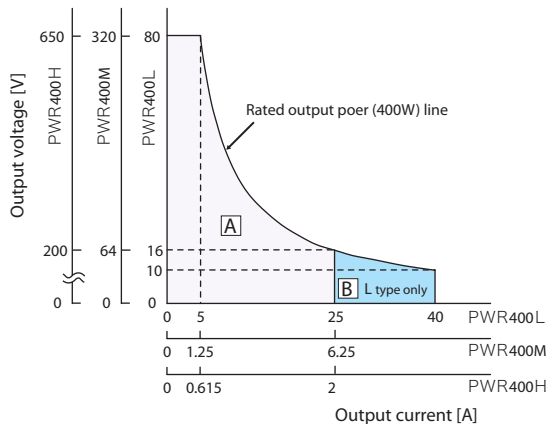

The output current must be derated with respect to the temperature at ambient temperatures greater than or equal to 45 °C (30 °C when operating in the extended operating area) on the L type and 40 °C on the M/H type.

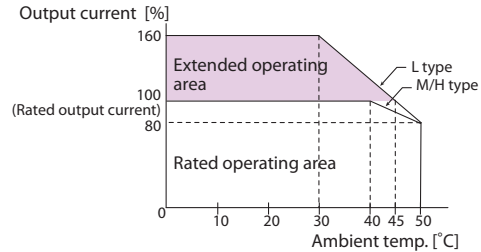

Extended operating area (L type only)

Of the output current setting range of the PWR as illustrated in figure below, the range between the rated output current and the maximum output current (160 % of the rating) is the extended operating area. The specifications of load fluctuation, input fluctuation, ripple/noise, and so on are not met in the extended operating area.

The extended operating area is divided into the continuous extended operating area and the intermittent extended operating area.

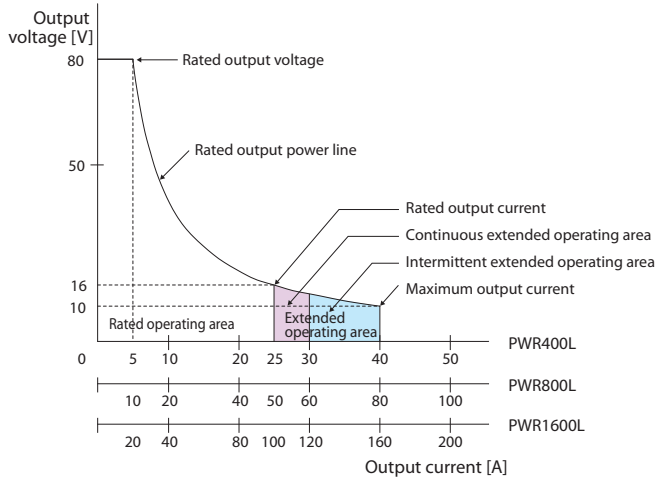

- **Extended operating area**
Continuous output is possible. At ambient temperatures greater than or equal to 30 °C, the output current must be derated with respect to the temperature.
- **Continuous extended operating area**
The output duration is limited.
Guideline of the time duration of operation (When operating by itself with no devices that generate heat around the PWR.)

Maximum Output Duration: 10 minutes

Pause Duration: At least twice the output duration

When using the PWR in the extended operating area, pay attention to the ambient temperature, preset current, and output duration.

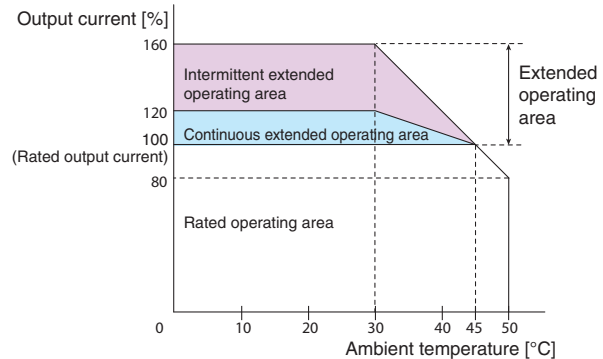

Precautions Concerning Installation

This product cannot be used while it is on its side.

The feet on the side panel of the 1600 W type are for temporarily laying the unit on its side before carrying the unit by the handle.

Do not use or store the unit on its side as it may tip over.

Safety Precautions

There is a warning label affixed to the product. If this label tears or falls off, replace with a new label. If you need a new label, contact your Kikusui agent or distributor.

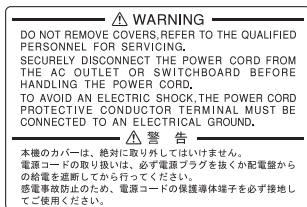

400W type left side panel



800W type top side panel

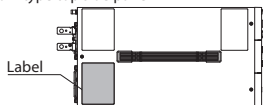

1600W type top panel

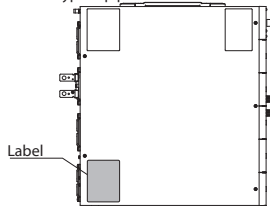

Connecting the Power Cord

The power cord provided with the PWR varies depending on the output capacity type. For the procedure to connect the power cord, see the respective section for each type. This product is designed as an equipment of IEC Overvoltage Category II (energy-consuming equipment supplied from the fixed installation).

⚠ WARNING

Possible electric shock.

- **This product is an IEC Safety Class I equipment (equipment with a protective conductor terminal). Be sure to ground the product to prevent electric shock.**
- **Connect the ground terminal to earth ground.**

400 W and 800 W types

- Note -

- Use the supplied power cord to connect to the AC line. If the supplied power cord cannot be used due to the rated voltage or the plug shape, replace it with an appropriate power cord of length 3 m or less.
- The rated voltage of the power cord with a three-prong plug that comes with the PWR is 125 VAC. If you are using an input power supply of a 200-V system, exchange the power cord with one that is suitable for the input voltage.
- Have a qualified engineer select the appropriate power cord. If obtaining a power cord is difficult, consult your Kikusui agent or distributor.
- The power cord with a three-prong plug is used to disconnect the PWR from the AC line in an emergency. Connect the power plug to an easily accessible power outlet so that the plug can be removed from the outlet at any time. Be sure to allow enough space around the power outlet.
- Do not use the supplied power cord on other instruments.

1

Check that the AC power supply meets the nominal input rating of the PWR.

The voltage that can be applied is any of the nominal power supply voltages in the range of 100 Vac to 240 Vac. The frequency is 50 Hz or 60 Hz.

2

Check that the POWER switch is turned off.

3

Connect the power cord to the AC inlet on the rear panel.

4

Insert the power plug to a properly grounded power outlet.

Connecting the Power Cord (Cont.)

1600 W type

The power cord that is included with the 1600 W type can be used on either a 100-Vac or 200-Vac system.

⚠ WARNING

- **Possible electric shock. Turn off the circuit breaker of switchboard before connecting the cord.**
- **Possible Fire. Have a qualified engineer connect the power cord to the switchboard. The breaker of switchboard is required to meet requirement.**

⚠ CAUTION

Inside the product, protective circuits including input fuses are connected to match the polarity of the input terminal. Make sure the colors of the wires connected to the corresponding input terminals (L, N, and \oplus (GND)) are correct.

- Note -

Turn off the circuit breaker of switchboard to disconnect the PWR from the AC line in an emergency.

Circuit breaker of switchboard requirement

- Rated current: 30 A (100 V system) / 15 A (200 V system)
For safety, breakers whose rated current exceeds the specified current cannot be used
- Dedicate the circuit breaker for the PWR.
- Keep the switchboard easily accessible at any time.
- Require labeling to identify that the circuit breaker is dedicated for the PWR and disconnecting device.

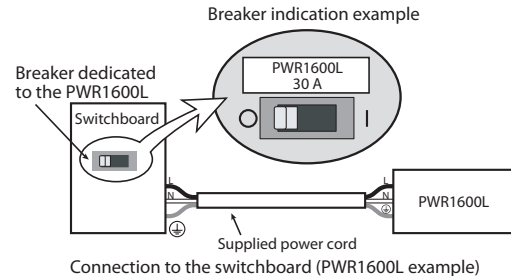

■ Procedure to connect the power cord

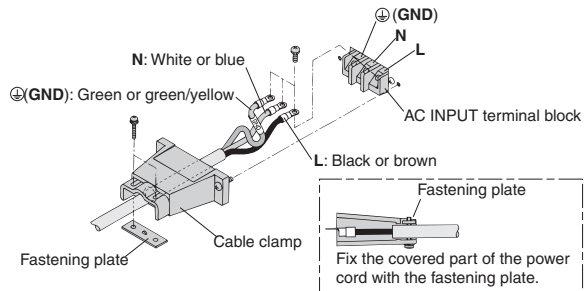

- 1 Check that the AC power line complies with the input rating of the PWR.**
The voltage that can be applied is any of the nominal power supply voltages in the range of 100 VAC to 240 VAC. The frequency is 50 Hz or 60 Hz.
- 2 Check that the POWER switch is turned off.**
- 3 Connect the power cord provided to the AC INPUT terminal block on the rear panel as shown in figure**
- 4 Attach crimping terminals at the switchboard end of the power cord.**
- 5 Turn the switchboard breaker off.**
- 6 Connect the power cord to match the L, N, and (GND) of the switchboard.**

Turning the Power On

Turn the power on without the load connected.

CAUTION

The CONFIG parameters can be set so that the output is automatically turned on when the POWER switch is turned on. When this function is enabled, the PWR powers up with the output turned on even if the output was off when the PWR was turned off the last time. There is a possibility that a load may break, if you connect a different load and turn the POWER and output on simultaneously without changing the OVP and OCP settings to appropriate values.

■ Turning the Power switch on

- 1 Check that the **POWER** switch is turned off.
- 2 Check that the power cord is correctly connected.
- 3 Turn the **POWER** switch on.

Push the (|) side of the POWER switch to turn the PWR on. If an odd sound, odd odor, fire, or smoke occurs around or in the PWR, remove the power plug from the outlet or turn the switchboard breaker off.

The voltmeter and ammeter show the firmware version for approximately 1 second. After a few seconds, the PWR is ready for operation (displays the output value).



Version display at power-on (ver.1.00 example)

If the POWER switch is turned on for the first time after purchasing the PWR, the PWR starts up in a factory default condition. For all other cases, the PWR starts up using the settings that existed when the POWER switch was turned off the last time.

Inrush current

An inrush current flows when the POWER switch is turned on. If you are planning to use several PWRs and turn on their POWER switches simultaneously, check that the AC power line or the switchboard has sufficient capacity. For the inrush current of each model, see “Specifications” of the user’s manual on the accompanied CD-ROM.

■ Turning the POWER switch off

Push the (○) side of the POWER switch to turn the PWR off.

The PWR stores the panel settings (excluding output on/off condition) immediately before the POWER switch is turned off. For these items, the PWR starts up using the settings that existed when the POWER switch was turned off the last time.

If the POWER switch is turned off immediately after changing the settings, the last settings may not be stored.



CAUTION

When turning the POWER switch off and then back on, allow at least 10 seconds after the panel display lights out. Repeated on/off of the POWER switch at short intervals can cause damage to the inrush current limiter and shorten the service life of the POWER switch and internal input fuse.

Load Considerations

Note that the output will become unstable if the following types of loads are connected.

■ Load current with peaks and pulse-shaped load current

The PWR indicates mean values. Even when the indicated value is less than the preset current value, the peak values may actually exceed the preset current value. If this happens, the PWR is instantaneously put into constant-current operation mode, and the output voltage drops accordingly.

For these types of loads, you must increase the preset current value or increase the current capacity.

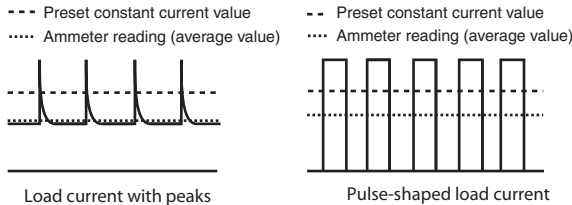

■ Load that generates reverse current to the power supply

The PWR cannot absorb reverse current from the load. Therefore, if a regenerative load (such as an inverter, converter, or transformer) is connected, the output voltage increases and becomes unstable.

For these types of loads, connect a resistor (RD) as shown in figure below bypass the reverse current. However, the amount of current to the load decreases by I_{rp} .

⚠ CAUTION

Select a resistor with sufficient rated power for RD. If a resistor with insufficient rated power for the circuit is used, RD may burn out.

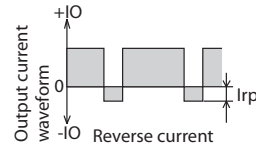
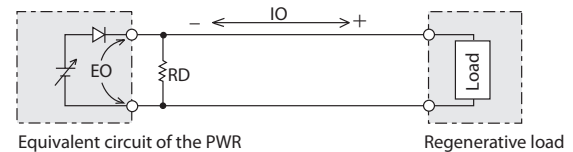

$$RD[\Omega] \leq \frac{E_o[V]}{I_{rp}[A]}$$

RD: Reverse current bypass dummy load
EO: Output voltage
Irp: Max. reverse current

■ Load with accumulated energy

Connecting a load with accumulated energy, such as a battery, to the PWR may cause current to flow from the load to the internal circuit of the PWR. This current may damage the PWR or degrade the service life of the load.

For this type of loads, connect a reverse-current-prevention diode (DRP) between the PWR and the load in series.



CAUTION

- To protect the load and the PWR, select a DRP that complies with the following conditions.

Reverse voltage withstand capacity of at least twice the rated output voltage of the PWR.

Forward current capacity that is 3 to 10 times the rated output current of the PWR.

A diode with small loss.

- Be sure to take into account the heat generated by DRP. DRP may burn out without adequate heat dissipation.

- Note -

Cannot be used in combination with remote sensing.

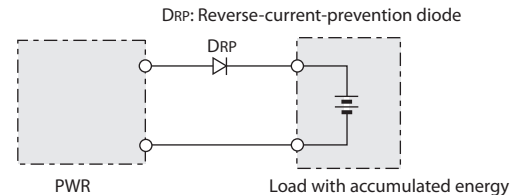

Load Wire

Note the following points concerning the wire used to connect the load.

WARNING

- To prevent fire, use a load wire with sufficient current capacity with respect to the rated output current of the power supply.
- Possible electric shock. Use a load wire with a higher voltage rating than the isolation voltage of the PWR. For the isolation voltage of each model, see “Specifications” of the user’s manual on the accompanied CD-ROM.

■ Current capacity of the load wire

If the current rating exceeds the maximum rated output current, the wire will remain intact even if the load is short-circuited. Load wires must be rated to carry the maximum rated output current of the PWR.

■ Allowable current of the wire dependent on the maximum allowable temperature of the cable insulation

The wire temperature is determined by a current-caused resistance loss, ambient temperature, and thermal resistance to the outside. Table shows the allowable capacity of current that can flow through a heat-resistant PVC wire (single wire) having a maximum allowable temperature of 60 °C when the wire is stretched horizontally in the air at an ambient temperature of 30 °C. If the condition is such that PVC wires with lower heat-resistant temperature are used, ambient temperature exceeds 30 °C, or the wires are bundled resulting in low heat radiation, the current capacity needs to be reduced.

■ Taking measures against noise

When connecting wires that have the same heat-resistant temperature, more current can flow by separating the wires to make heat radiation as great as possible. However, installing the + (pos.) and - (neg.) output wires side by side or bundling them together is more effective against unwanted noise. The Kikusui-recommended currents shown in Table are allowable current values that have been reduced in consideration of the potential bundling of load wires. Use these values as a guideline when connecting load cables.

■ Limitations of the sensing function

All wires have resistance. The voltage drop in wires becomes greater as the wire becomes longer or the current becomes larger. This results in the voltage applied at the load end to be smaller. The PWR has a sensing function that compensates for this voltage drop up to approximately 0.6 V for a single line. If the voltage drop exceeds this level, wires having a greater sectional area should be used.

Nominal cross-sectional area of wires and allowable currents

Nominal Cross-Sectional Area [mm ²]	AWG	(Reference Cross-Sectional Area) [mm ²]	Allowable Current* [A] (Ta = 30 °C)	Current Recommended by Kikusui [A]
2	14	(2.08)	27	10
3.5	12	(3.31)	37	-
5.5	10	(5.26)	49	20
8	8	(8.37)	61	30
14	6	(13.3)	88	50
22	4	(21.15)	115	80
30	2	(33.62)	139	-
38	1	(42.41)	162	100
50	1/0	(53.49)	190	-
60	2/0	(67.43)	217	-
80	3/0	(85.01)	257	200
100	4/0	(107.2)	298	-
125	-	-	344	-
150	-	-	395	300
200	-	-	469	-

*Excerpts from Japanese laws related to electrical equipment.

Connecting the Load

Connecting to the Output Terminal on the Rear Panel

⚠ WARNING

Possible electric shock. Be sure to turn the POWER switch off before touching the output terminal on the rear panel. Be sure to attach the OUTPUT terminal cover after wiring the load.

The chassis connection wire is not included. If you are using the chassis connection wire that comes with the analog remote control connector kit (OP01-PAS), you can use it immediately as it is already assembled.

1 Turn the POWER switch off.

2 Connect the chassis terminal to either the - (neg.) or + (pos.) output terminal using the chassis connection wire.

The output terminal has an M3 hole used to connect the chassis connection wire. If you are not using the optional OP01-PAS, attach a crimping terminal to a wire of AWG18 or higher to make the connection.

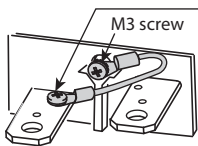

This M3 screw is fastened to the + (pos.) terminal before factory shipment. If you want to connect the chassis connection wire to the - (neg.) output terminal as shown in the figure, change it as such.

3

Attach crimping terminals to the load wires.

The output terminal on the rear panel has M4- (with taps) and M8-sized holes for connecting the load wires. Attach the crimping terminal that matches the screws. Use crimping terminals that are less than equal to 5.5 mm² with the M4-sized holes.

4

Connect the load wire to the output terminal on the rear panel.

If you are using M8 screws, pay attention to the direction of the screws.

Connection using M4 screws

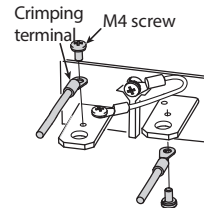

Do not fasten M4 screw without attaching the load wire. Otherwise the threads of the output terminal may be damaged.

Connection using M8 screws

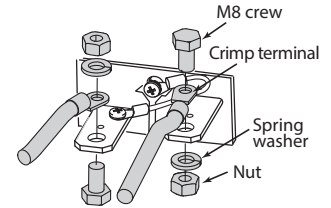

If you do not connect the wire as shown, the OUTPUT terminal cover may hit the M8 screw.

Attaching the OUTPUT terminal cover

There are two types of OUTPUT terminal covers: bottom cover and top cover.

- 1 Insert the hook of the bottom cover into the hole located above and to the left of the output terminal.**

The bottom cover is the one without screws.

- 2 Align the hook of the bottom cover to the groove located to the side of the output terminal.**

- 3 Align the bottom cover with the top cover, and fix them in place using the screws attached to the top cover.**

Check that the screws are securely fastened.

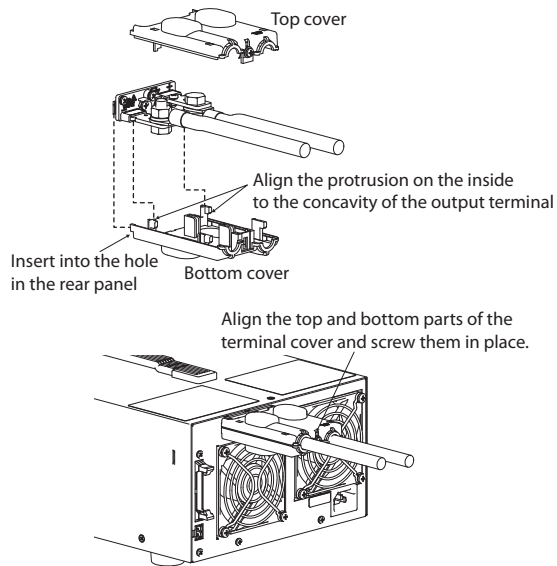

Connecting the Load (Cont.)

Connection to the Output Terminal on the Front Panel

The specifications of the PWR are defined for output terminal on the rear panel. Those on the front panel may not satisfy the specifications.

Like the output terminal on the rear panel, the chassis terminal is normally connected to either the - (neg.) or + (pos.) output terminal.

WARNING

- **Possible electric shock. Be sure to turn the POWER switch off before touching the output terminal on the front panel. Do not use the terminal with the front output terminal cover removed. In addition, be sure to attach the OUTPUT terminal cover on the rear panel.**
- **Possible overheating or fire. Do not supply currents that exceed 30 A from the output terminal on the front panel on the L type.**

If the front output terminal cover is damaged or lost, contact Kikusui distributor/agent.



[P1-000-408]

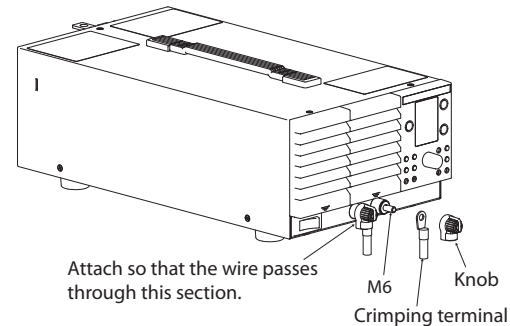

- 1 Turn the POWER switch off.**
- 2 Attach crimping terminals to the load wires.**
- 3 Remove the knob and connect the load wire to the output terminal on the front panel.**
- 4 Attach the knob.**

■ Trademarks

Microsoft, Windows, and Visual Basic are registered trademarks of Microsoft Corporation in the United States and/or other countries.

All company names and product names used in the PWR manual are trademarks or registered trademarks of their respective companies.



环境保护使用期限
Environment-friendly Use Period

该标记为适用于在中华人民共和国销售的电子信息产品的环境保护使用期限。

只要遵守有关该产品的安全及使用注意事项，从制造年月起计算，在该年度内，就不会对环境污染、人身、财产产生重大的影响。

产品的废弃请遵守有关规定。

产品的制造年月可以在以下网址中确认。

<http://www.kikusui.co.jp/pi/>

有毒有害物质或元素名称及含有标示

Name of hazardous materials and symbol of element in the equipment and quantity

部件名称 Name of part	有毒有害物质或元素 Hazardous material and symbol of element					
	铅 Pb	汞 Hg	镉 Cd	六价铬 Cr(VI)	多溴联苯 PBB	多溴二苯醚 PBDE
印刷电路板组装机 Printed circuit board assemblies	×	○	×	×	○	○
内部接线 Internal wirings	×	○	×	×	○	○
外壳 Enclosure	×	○	×	○	○	○
底盘组装机 Chassis assembly	×	○	×	×	○	○
辅助设备 Accessories	×	○	○	○	○	○

本表格依据 SJ/T 11364 的规定编制。

- ：该部件所有均质材料的有毒有害物质的含量不超过 GB/T 26572 标准所规定的极限值要求。
- ×：该部件至少有一种均质材料的有毒有害物质的含量超过 GB/T 26572 标准所规定的极限值要求。